













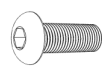

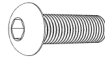
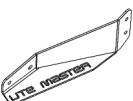
UTE MASTER

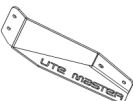
HILUX

FITTING INSTRUCTIONS FOR UTEMASTER CENTURION ALUMINIUM CANOPY





FITTING KIT CONTENTS

	1x PRT-003265L		1x PRT-001473R		12x M8 x 25mm bolts
	1x PRT-003265R		1x PRT-001473L		8x M8 x 35mm bolts
	1x PRT-003266L		1x PRT-002321L		24x M8 20mm washers
	1x PRT-003266R		1x PRT-002321R		4x M8 nyloc nuts
	2x PRT-003268		2x M6 barrel nuts		16x M8 spring washers
					2x M6 x 50mm bolts
					2x M6 spring washers

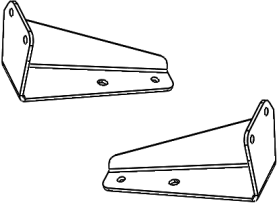
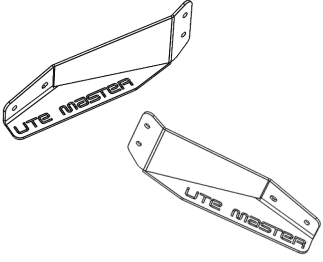
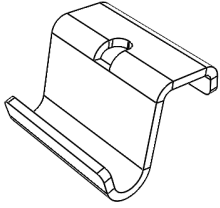
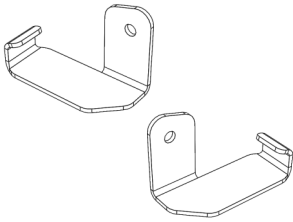
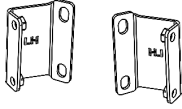
KIT CONTENTS

<p>1 Fitting Instructions</p> 	<p>2 Front mounting brackets</p> 	<p>3 Rear mounting brackets</p> 	<p>4 Clamping brackets</p> 
x1	PRT-003265L, PRT-003265R x1 ea	PRT-003266L, PRT-003266R x1 ea	PRT-003268 x2
<p>5 Tailgate brackets</p> 	<p>6 Liner adaptor brackets</p> 		
PRT-001473L, PRT-001473R x1 ea	PRT-002321L, PRT-002321R x1 ea		

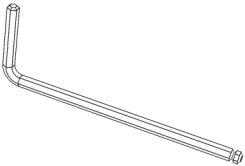
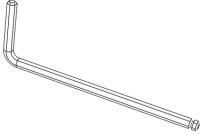
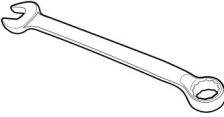
TOOLS REQUIRED

<p>1 Hex Key 5mm</p> 	<p>2 Hex Key 4mm</p> 	<p>3 13mm Spanner</p> 	<p>4 10mm Spanner</p> 
<p>5 Phillips Screwdriver</p> 			

STEP
1

Remove the wellside hooks from the rear corners

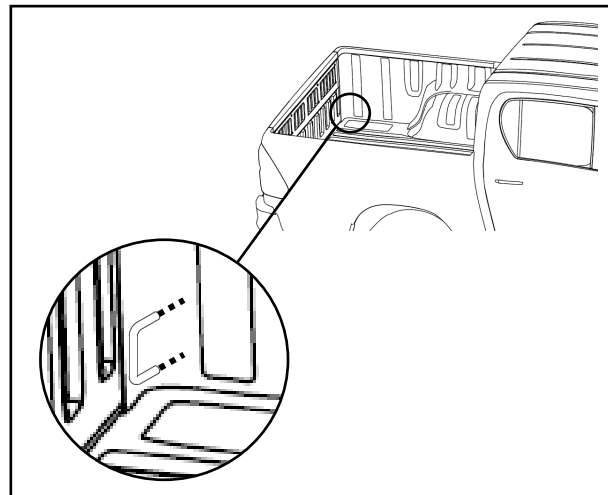

STEP
2

Remove the wellside hooks from the front corners

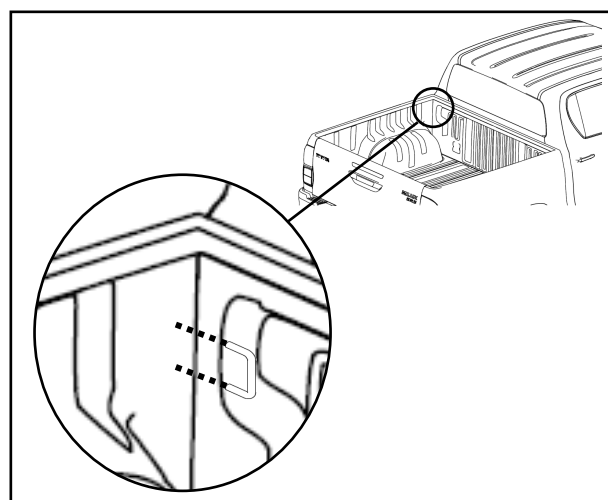

STEP
3

If you have a Sportsguard liner, install the spacer brackets 'PRT-002321L' & 'PRT-002321R' before installing the front brackets shown on the right. These brackets pack out the gap between liner and wellside wall.

Standard liners do not require these brackets and can be discarded along with any surplus fasteners.

Mounting the bracket or spacer bracket direct to the wellside using:

- **M8x35** Button Head Bolt
- M8 Spring Washer
- M8 Standard Washer

Mounting the bracket to the spacer using:

- **M8x25** Button Head Bolt
- M8 Spring Washer
- M8 Standard Washer

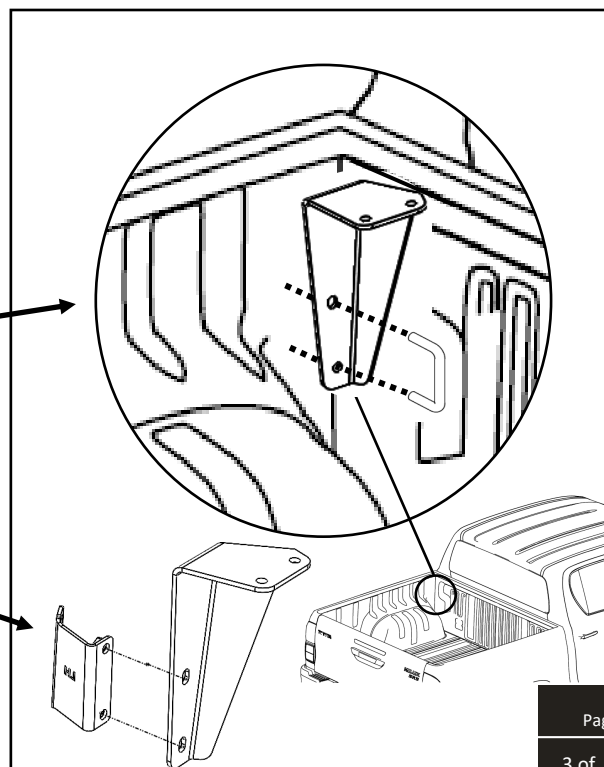

STEP
4

Lift the canopy onto the vehicle.

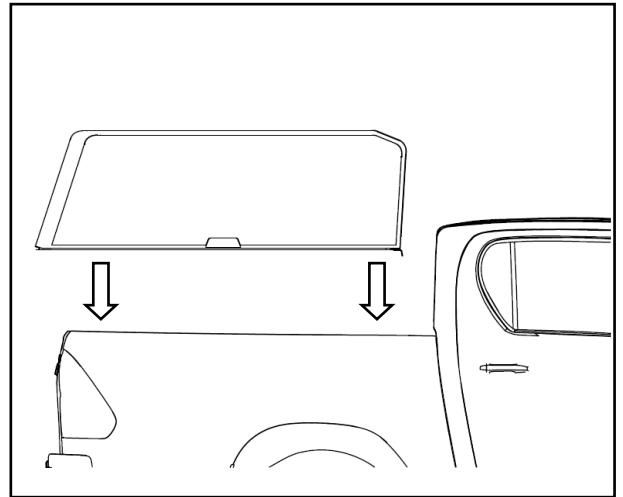

STEP
5

Move the canopy towards the rear until the flange at the front touches the front edge of the wellside.

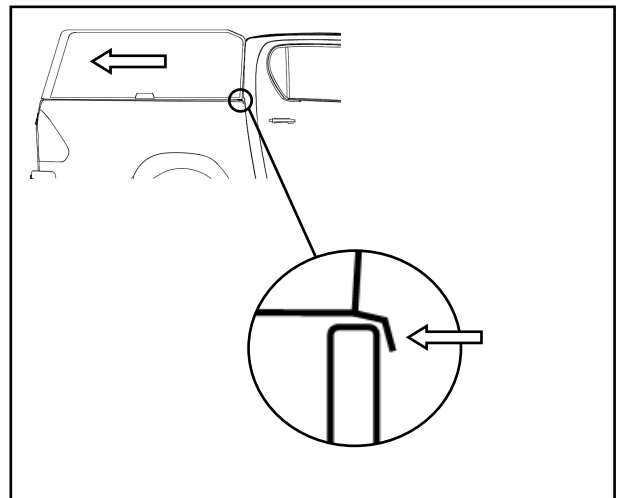

STEP
6

Remove the 2x bolts on each side at the rear corner of the canopy. These can be discarded.

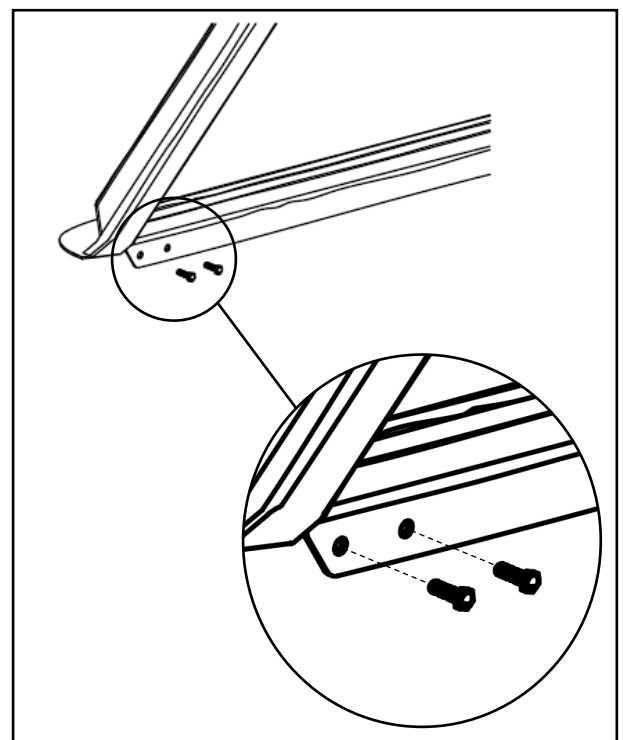

STEP
7

Install the rear tie points through the brackets using:

- M8x35 Button Head Bolts
- M8 Spring Washers
- M8 Standard Washers

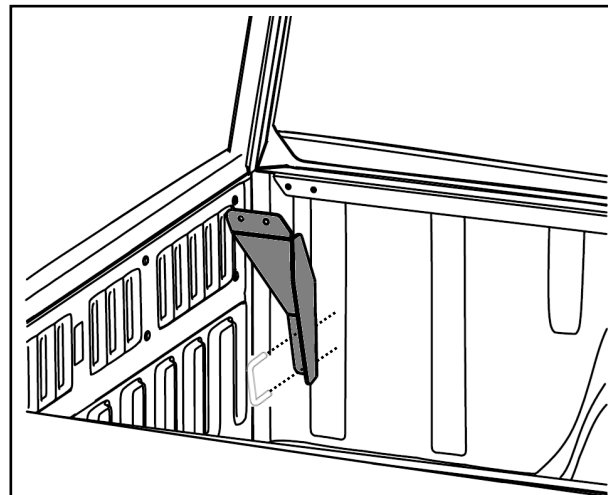

STEP
8

Secure the canopy to the mounting brackets using:

- M8x25 Button Head Bolts
- M8 Medium Washers
- M8 Spring Washers

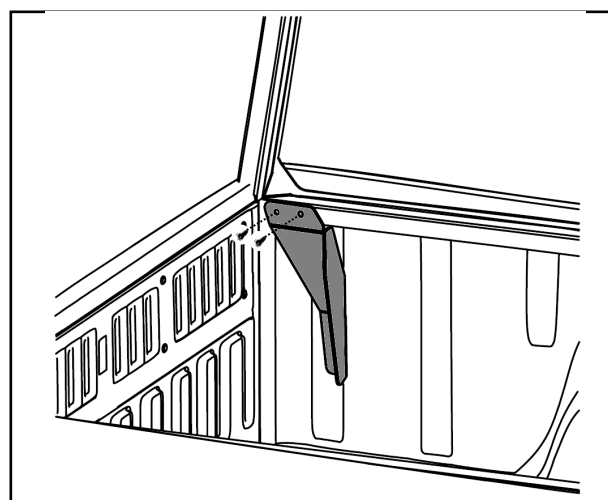

STEP
9

Bolt the canopy to the front mounting brackets using the following fasteners:

- M8 x 25mm button head bolts
- M8 20mm washers
- M8 nyloc nuts

Tighten until the canopy is being held down firmly onto the vehicle, ensure the bulb seal around the perimeter is being compressed

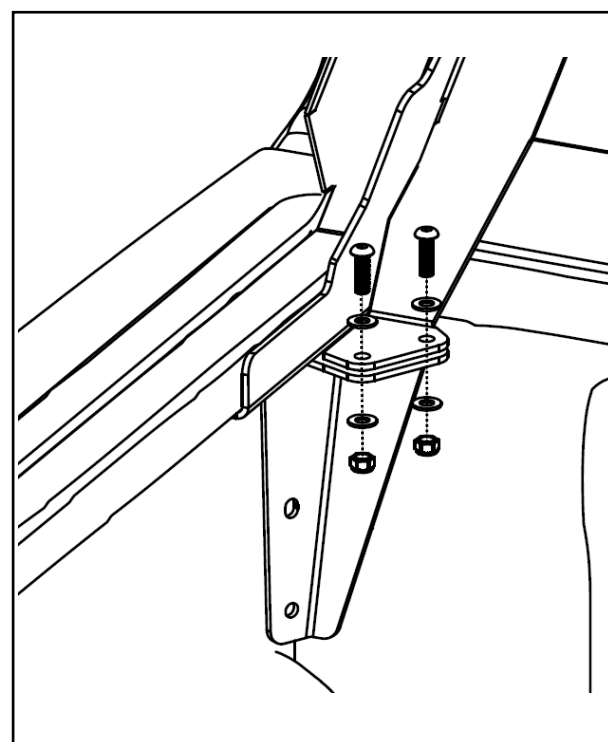

STEP
10

Install the clamping tabs through the slots in each side

Secure in place using the following fasteners:

- M6 x 50mm button head bolt
- M6 spring washer
- M6 barrel nut

The clamping tab should curl around the wellside lip as shown

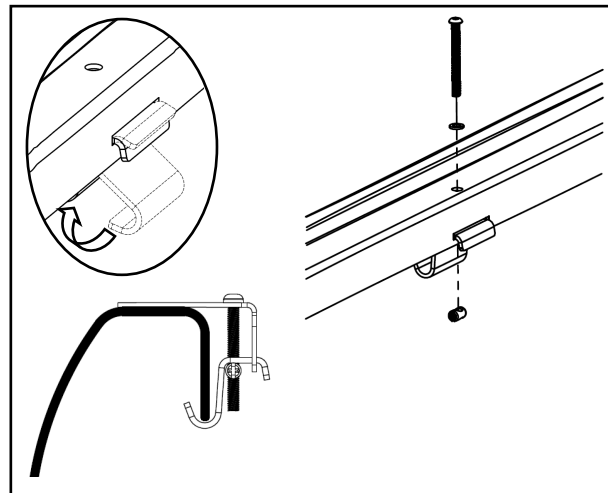

STEP
11

IMPORTANT CHECK:

Check the clearance between the side doors and the faceplates. This should have approx. 2-3mm clearance.

If it is touching or less than 2mm, slightly loosen off the bolts in the front mounting bracket (see Step 9).

The wellside is curved so if the tension at the front is released slightly then it will increase the door clearance.

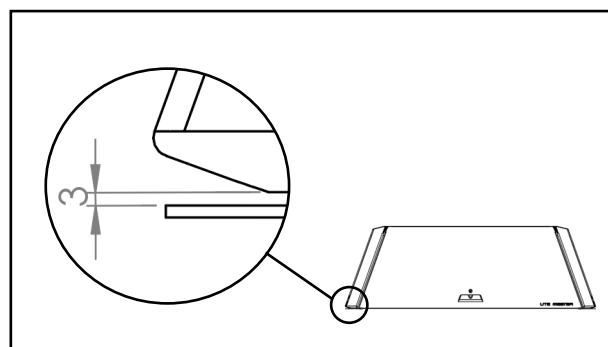

STEP
12

Connect the central locking to the wiring in the canopy (if applicable)

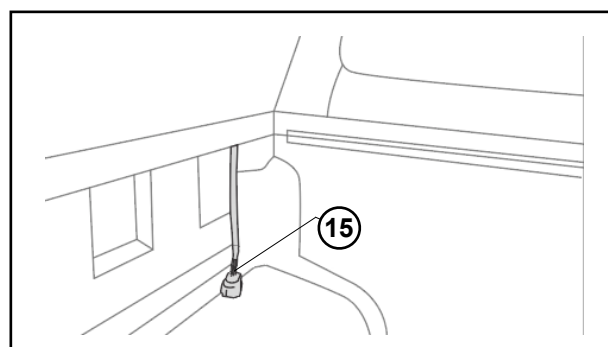

STEP
13

Remove the bolt and bump stop from the side of the tailgate.

Reinstall the tailgate bump stop over top of the tailgate brackets using the original bolts

