

# Volkswagen Amarok 2023+ LLX-VWB3SB-E

## Sports Bar Load-Lid™



[bit.ly/3NpsAtV](https://bit.ly/3NpsAtV)



### Despatch List:

ID#	DESCRIPTION	IMAGE	QTY
1	PRT-006891-01 <i>(with sponge gaskets installed)</i>		1x
2	PRT-005962R PRT-005962L		1x 1x
3	PRT-006889L PRT-006889R		1x 1x
4	PRT-004286		4x
5	PRT-005961		2x
6	PRT-005963		2x

ID#	DESCRIPTION	IMAGE	QTY
7	SS0610-5M		1x
8	M8 x 25mm Btn Bolt		20x
9	M8 Spring Washer		16x
10	M8 Medium Washer		12x
11	M8 Fender Washer		8x
12	M8 Nyloc Nut		4x

1

Remove the sports bar from the vehicle.

2

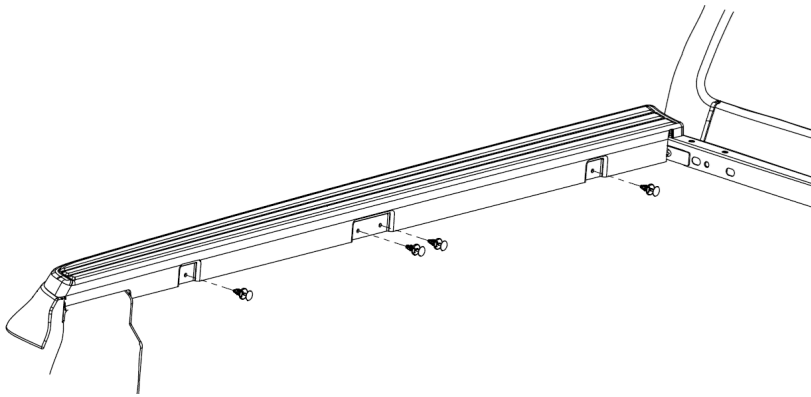

Remove the clips along the side of the plastic caps.

Repeat for both sides.

3

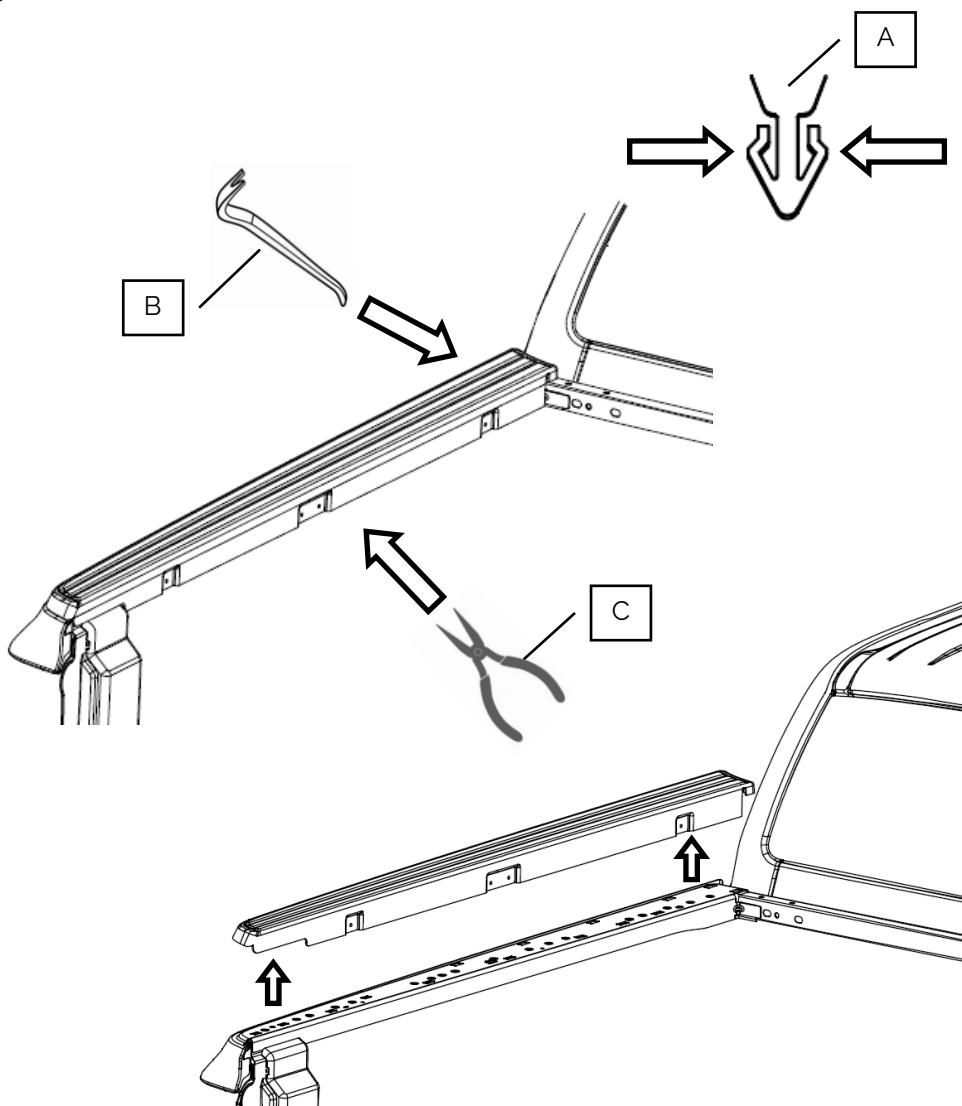

Remove the plastic caps along the sides of the wellside.

The clips need to have at least one side pushed inwards to release the clip (A).

Some clips need a prying tool (B) inserted under the outside of the caps to release the clips, particularly in the front and rear corners, however most of the clips holding the caps in place can be accessed from inside the wellside using pliers (C).

Take care not to damage the clips or the caps, these will be re-installed later.

Repeat for both sides.

4

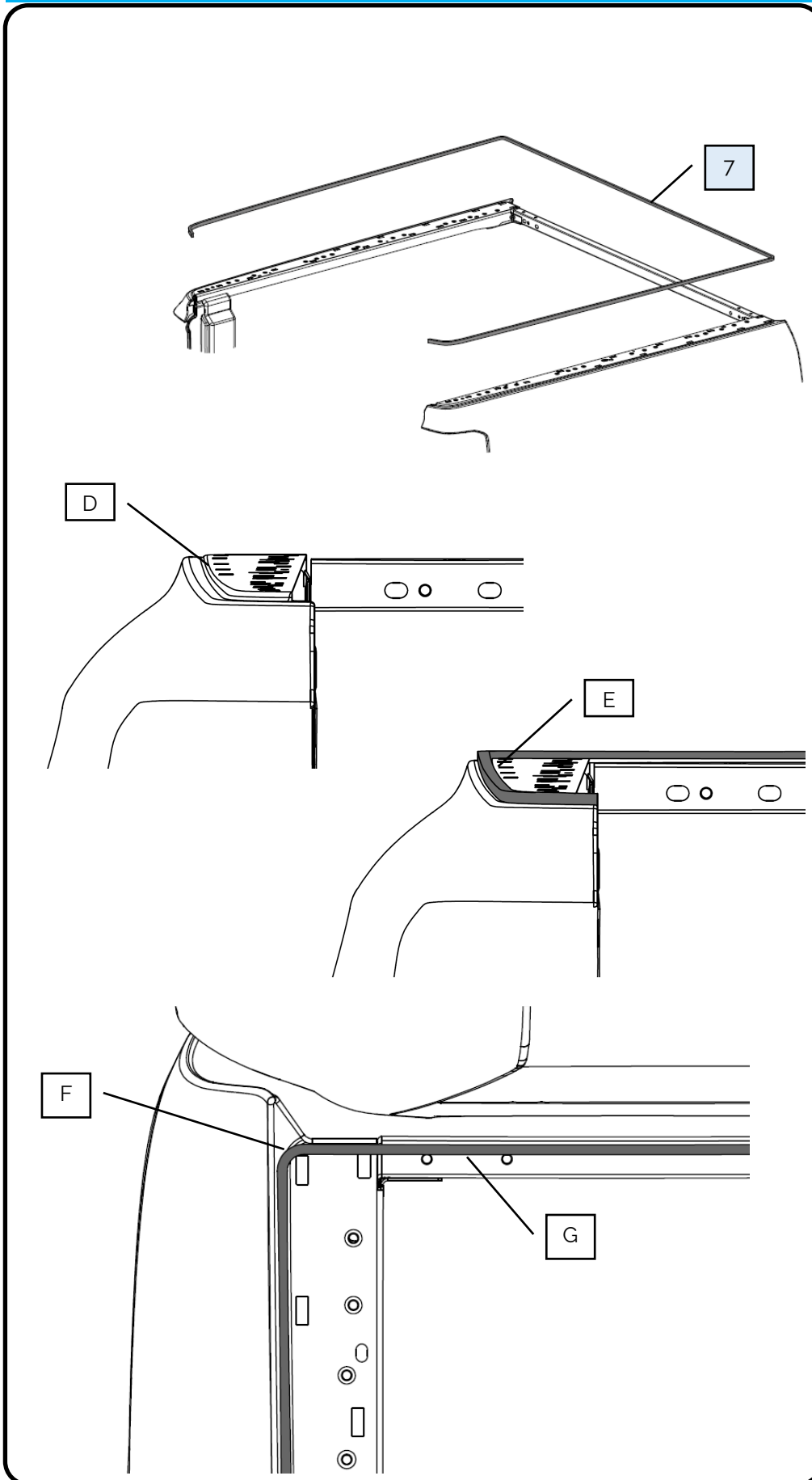

Run the provided sponge seal around the outside of the wellside in a continuous seal, starting at the tailgate on one side and ending at the tailgate on the other side.

Use the raised section (D) along the sides as a guide, the sponge seal should touch the raised section (E).

In the front corners, the sponge seal should turn the corner and run along the front of the wellside (F).

Ensure the sponge seal is in front of the threads (G).

5

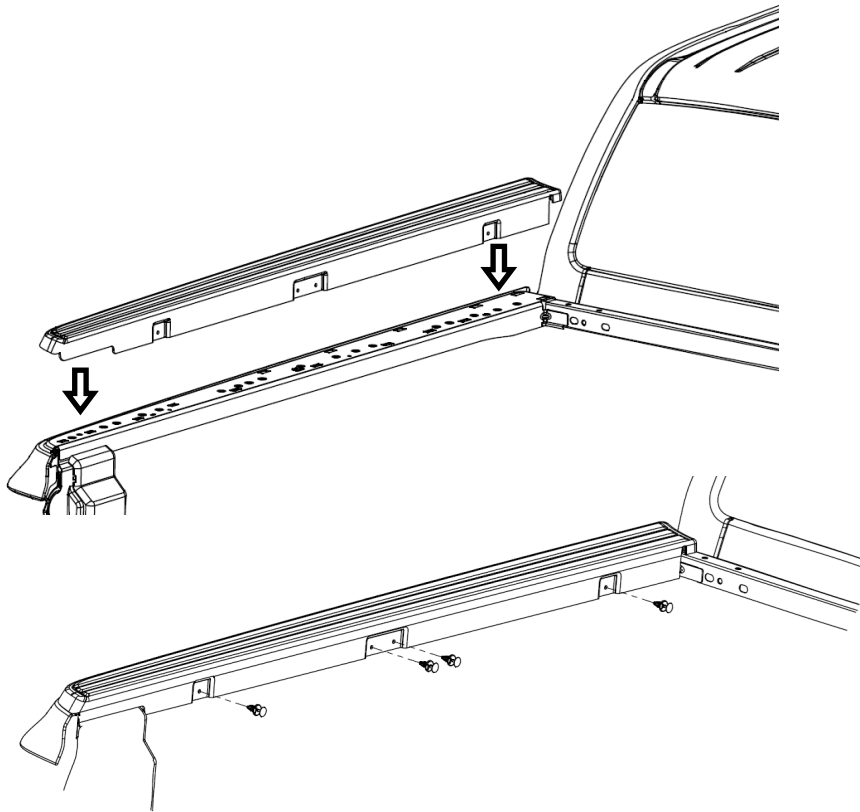

Return the plastic caps to their original position, these should clip back in place.

The caps should compress the sponge seal, but ensure it doesn't bulge out underneath the caps.

Also return the clips to their original position (see Step 1).

Repeat for both sides.

6

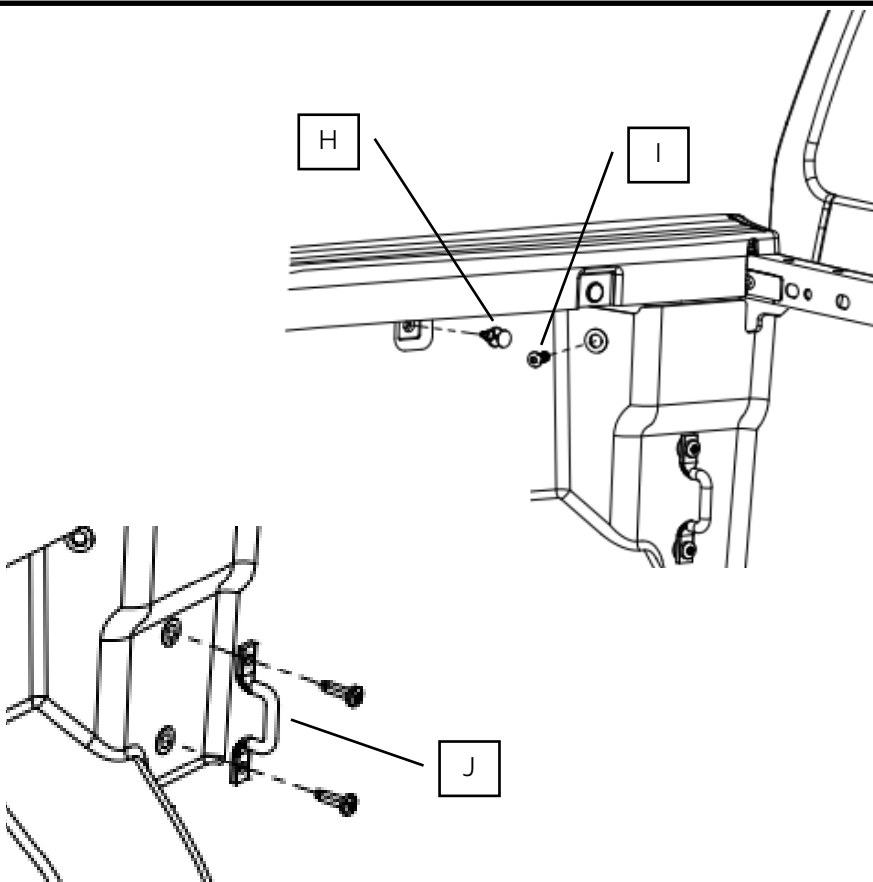

If you have a plastic wellside liner, remove the front clip (H) and bolt (I) holding the liner in the front corner.

Remove the hooks from the front corner (J).

Repeat for both sides.

7

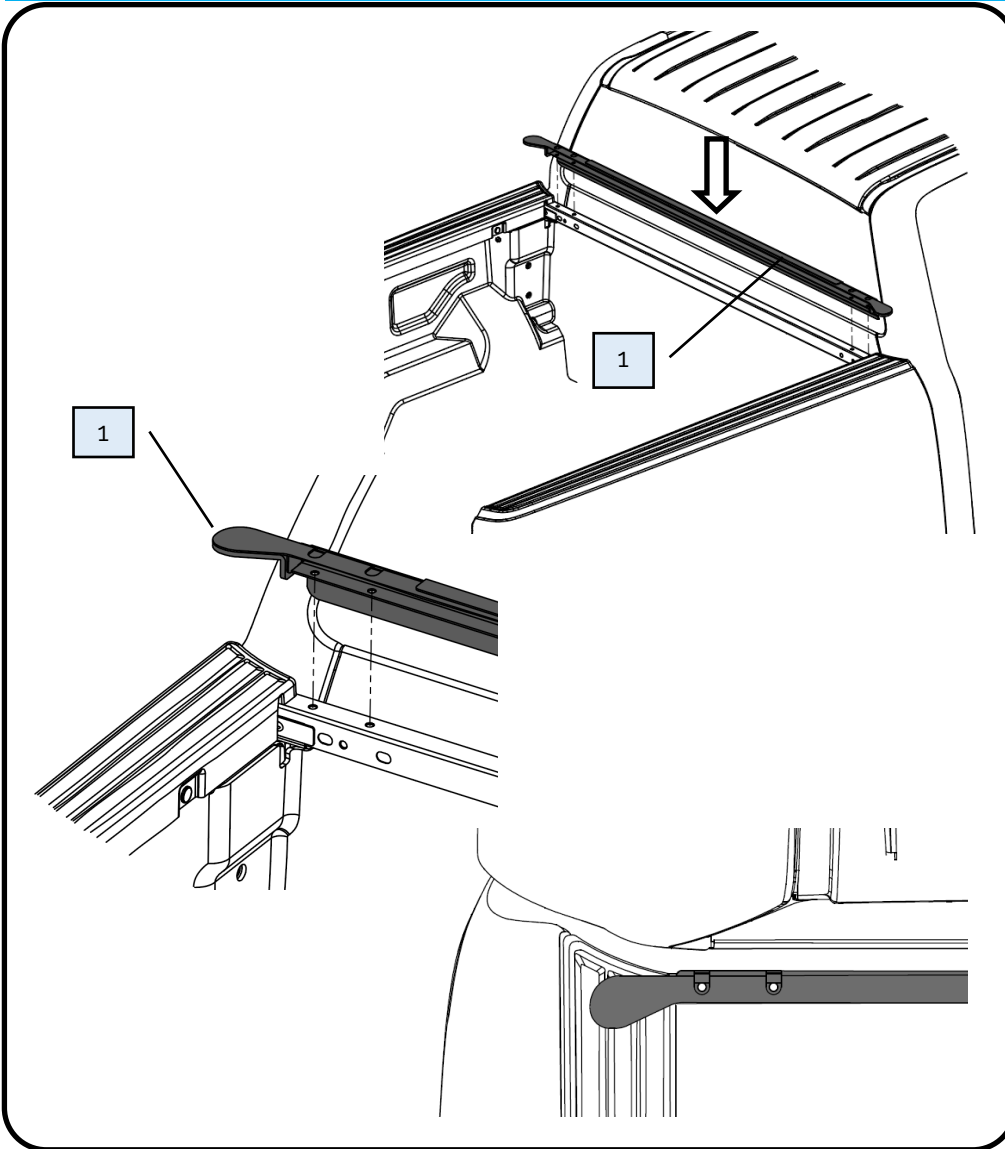

Install the front infill bracket PRT-006891 to the front wall of the wellside, between the two plastic caps.

Take care not to scratch the cab when installing.

Ensure the foam compress tightly and leave no gaps.

8

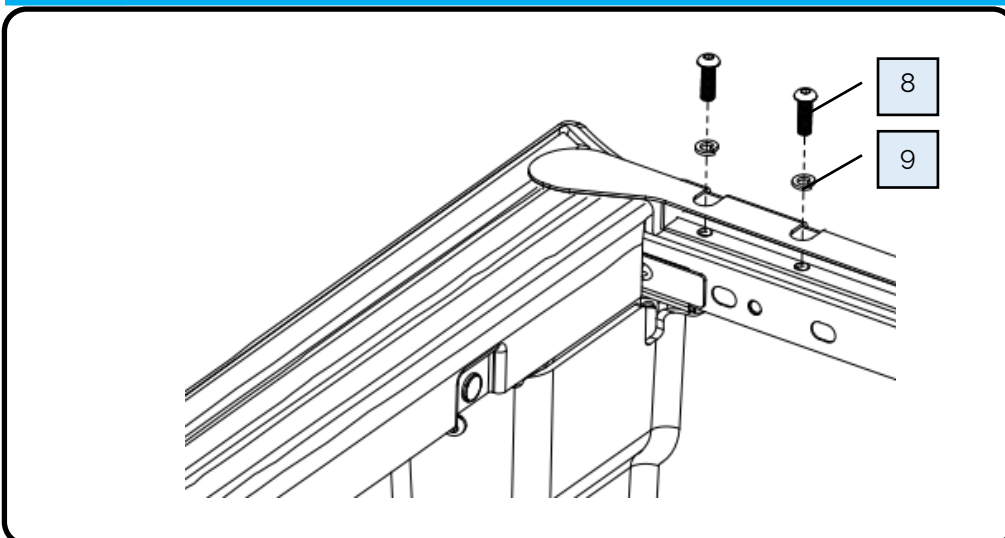

Bolt the infill bracket in place using the following fasteners:

- 8) M8 x 25mm Btn Bolt
- 9) M8 Spring Washer

Repeat for both sides.

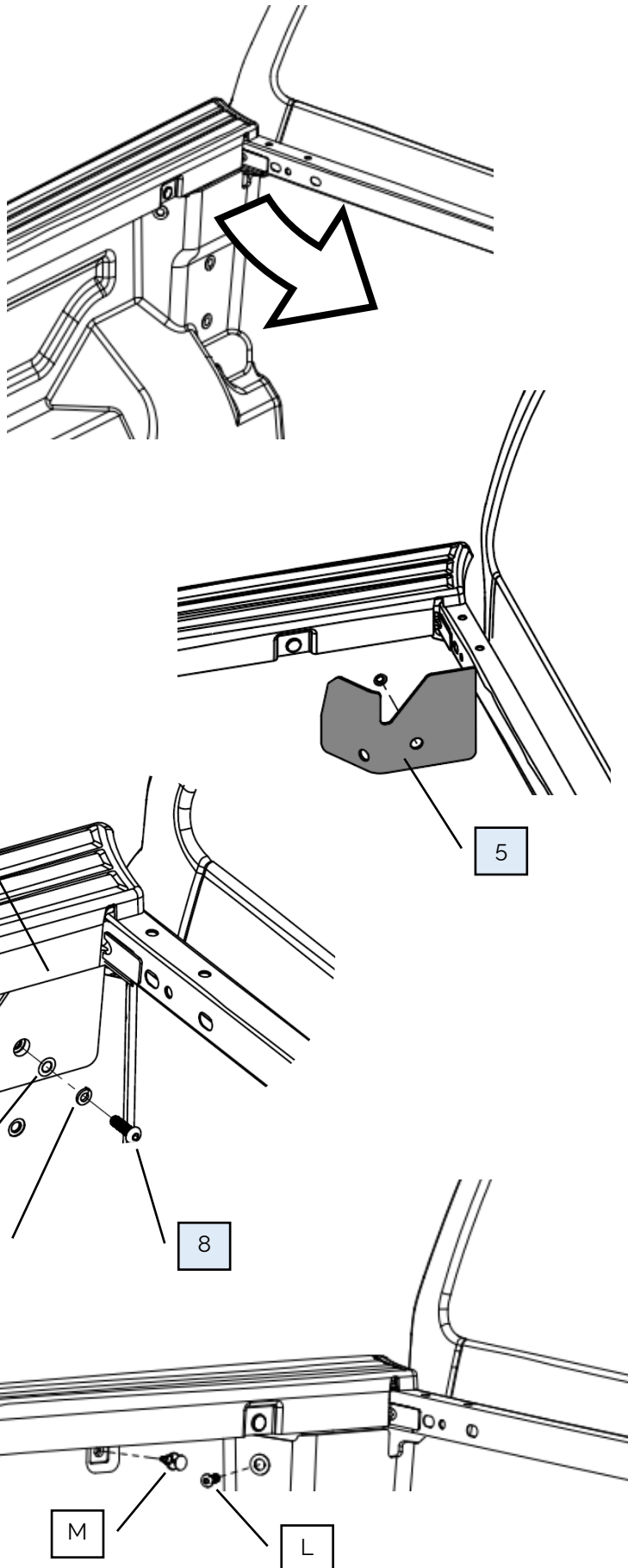

**This step is only relevant for plastic wellside liners, spray liners will need a separate sealing kit**

Pull the front corner of the liner away from the wellside wall to give access behind.

Insert the provided rubber gasket. This should sit inside the plastic cap (K). Bolt in place to the front thread using the following fasteners:

- 8) M8 x 25mm Btn Bolt
- 9) M8 Spring Washer
- 10) M8 Medium Washer

Do not overtighten, or the bolt head will pull through the rubber.

Return the liner to its original position, sitting over top of the rubber gasket.

Return bolt (L) to its thread, this should pass through the hole in the rubber gasket.

Re-insert the plastic liner clip (M).

Repeat for both sides.

10

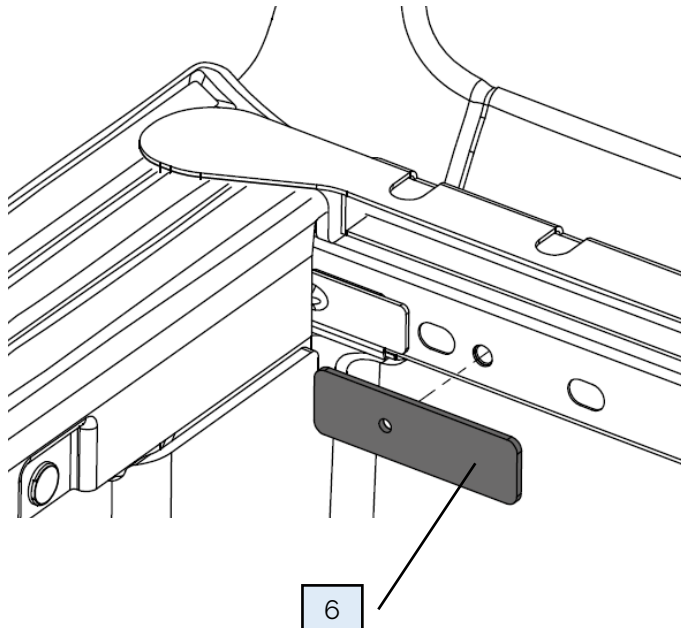

Install PRT-005963 onto the front wall to cover up the open slotted holes.

Ensure the hole in the foam gasket lines up with the thread in the front wall, and that it covers both slotted holes.

Repeat for both sides.

11

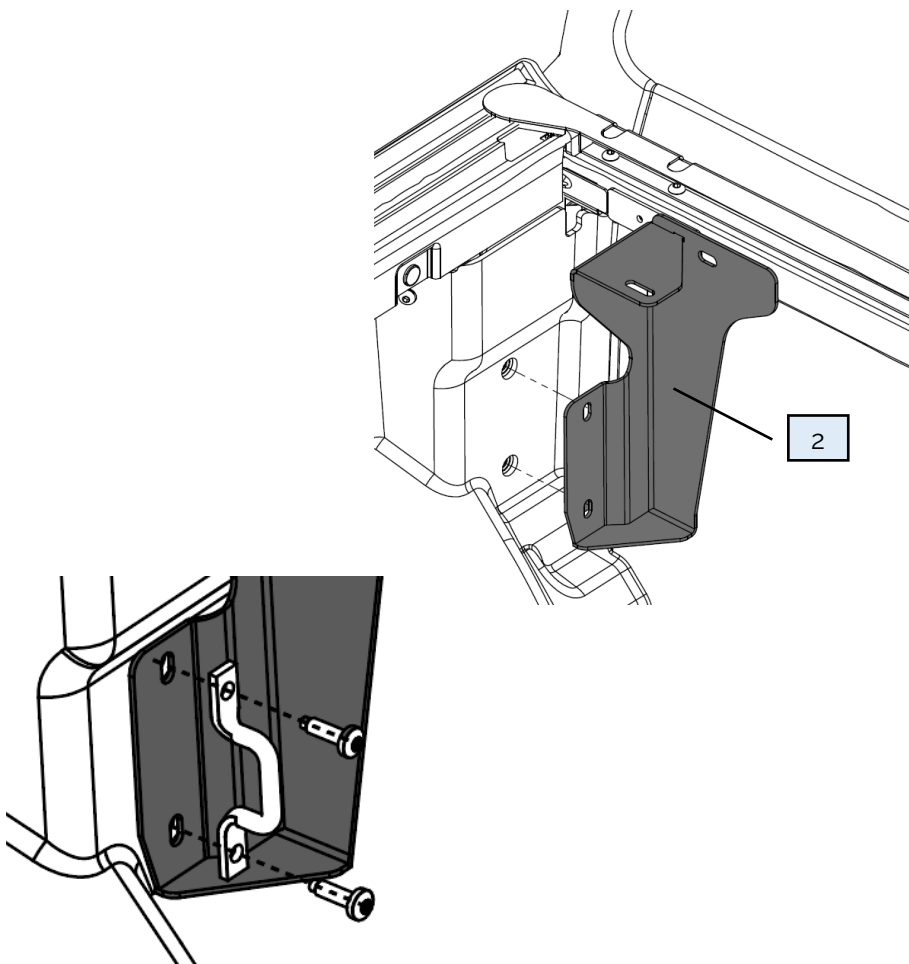

Install the front mounting brackets PRT-005962 into the front corners.

Re-install the hook and bolts through the brackets, leave loose at this stage.

Repeat for both sides.



12

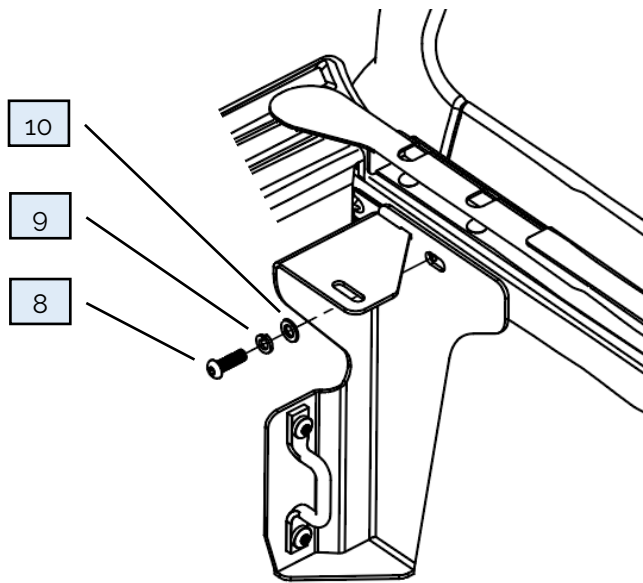

Bolt into the front wall thread using the following fasteners:

- 8) M8 x 25mm Btn Bolt
- 9) M8 Spring Washer
- 10) M8 Medium Washer

Tighten these bolts and the hook bolts (from previous step).

Repeat for opposite side.

13

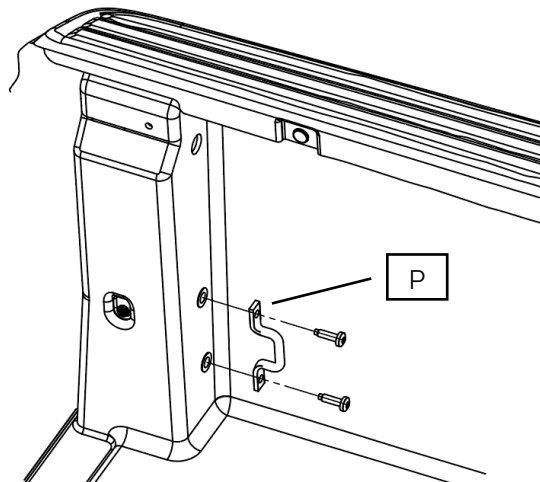

Remove the hooks from the rear corners (P).

Repeat for opposite side.

14



Install the rear mounting brackets PRT-006889 into the rear corners.

Bolt in place using the original hook and bolts from the previous step.

Repeat for opposite side.



15

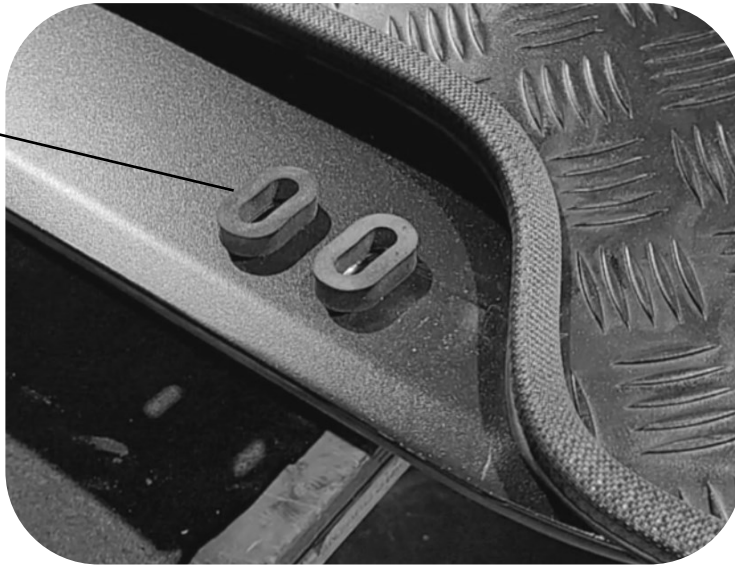

Place the foam gaskets PRT-004286 over the slots in the Load-Lid face plate.

16



Lift the sports bar onto the Load-Lid.

17



Bolt the front feet of the sports bar to the Load-Lid brackets, using the following fasteners:

- 8) M8 x 25mm Btn Bolt
- 9) M8 Spring Washer
- 10) M8 Medium Washer

Repeat for opposite side.

18



Replace plastic caps over the front feet cut-outs.

19



Bolt the rear feet of the sports bar to the Load-Lid through the face plate, using the following fasteners:

- 8) M8 x 25mm Btn Bolt
- 9) M8 Spring Washer
- 10) M8 Medium Washer

Repeat for opposite side.

20

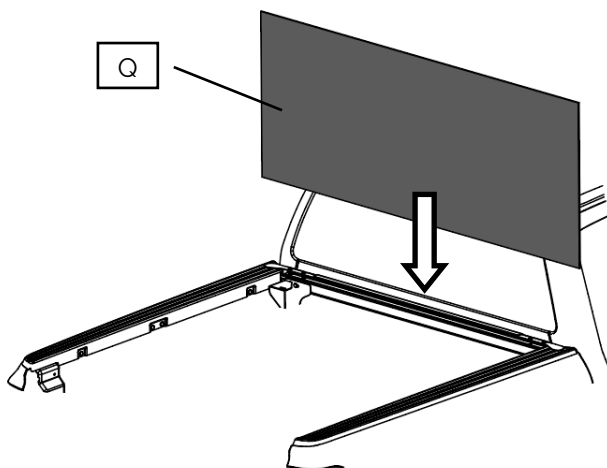

Insert cardboard (Q) between the cab and wellside to protect the paint from scratching during installation.

*Note: Cardboard not supplied.*

21



Lift the Load-Lid onto the vehicle.

22

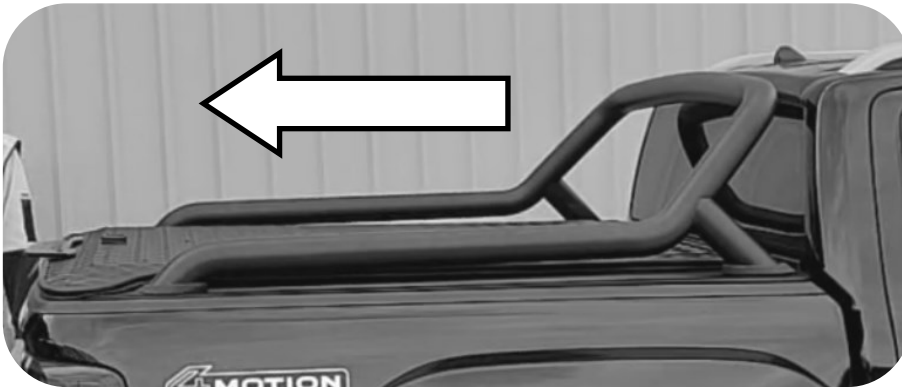

Ensure Load-Lid is pulled back as far as possible.

23



Bolt the Load-Lid to the rear mounting brackets using the following fasteners:

- 8) M8 x 25mm Btn Bolt
- 11) M8 Fender Washer
- 12) M8 Nyloc Nut

Repeat for opposite side.

24



Bolt the Load-Lid to the front mounting brackets using the following fasteners:

- 8) M8 x 25mm Btn Bolt
- 11) M8 Fender Washer
- 12) M8 Nyloc Nut

Repeat for opposite side.

25



<https://wi.st/2Bp7XJg>

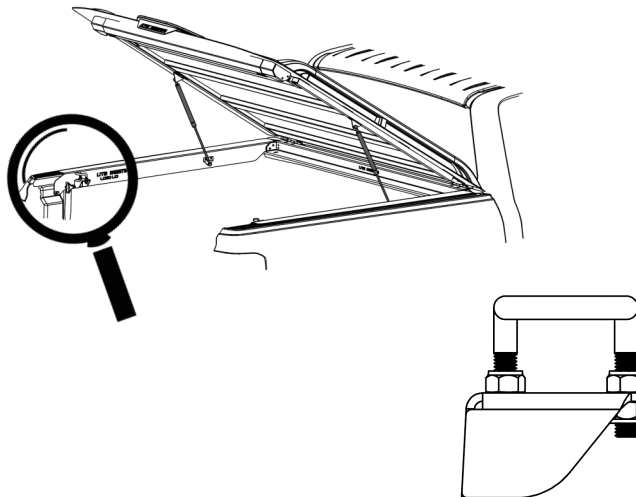

Adjust the nuts on the lock strike to affect the final closing height of the Load-Lid.

Refer to the video shown on the QR code for details.