

VW Amarok 2023+ CANOPY-VWB3 Centurion Canopy



Installation
video

bit.ly/3Vo8t1d



Fitting Time:
30-60 minutes

Despatch List:

ID#	DESCRIPTION	IMAGE	QTY
1	PRT-006894 (VWA) <i>(with bulb seal installed)</i>		1x
2	PRT-005979R PRT-005979L		1x 1x
3	PRT-006870R (VWA) PRT-006870L (VWA)		1x 1x
4	PRT-005961		2x
5	PRT-005963		2x
6	PRT-005990		4x

ID#	DESCRIPTION	IMAGE	QTY
7	M8 x 25mm Btn Bolt		14x
8	M8 Spring Washer		8x
9	M8 Medium Washer		12x
10	M8 Fender Washer		10x
11	M8 Nyloc Nut		8x
12	M8 x 16mm Btn Bolt		2x

IMPORTANT WARRANTY MESSAGE:

The warranty on this canopy is only valid if there has been a VW Approved Tub Brace kit installed on the vehicle. If this is not installed the warranty on the vehicle may not be valid.



Any steps marked with the alert symbol are critical steps for removing or refitting existing vehicle bolts. These bolts have a thread locking glue, and can become jammed and snap when force is applied. Recommended procedure is to use a heat induction tool to loosen the bolts, alternatively use Förc'h Black Magic to lubricate the thread. Gently work the bolt backwards and forwards in the thread using hand tools to 'crack' the thread locking glue. Slowly extract the bolt using hand tools. Take equal care when refitting the bolts, ensure the bolt is clean and the thread is lubricated. Bolts may require heating to soften the glue before refitting. **DO NOT FORCE THE BOLT IF JAMMED.** Take the vehicle to a specialist if the problem persists.

1

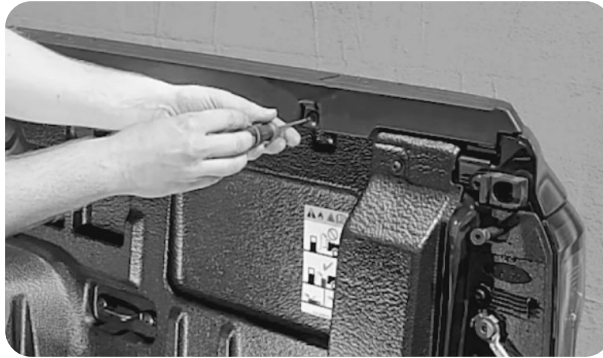

Remove the clips along the side of the plastic caps.

Repeat for both sides.

2



Remove the plastic caps along the sides of the wellside.

The clips need to have at least one side pushed inwards to release the clip.

Some clips need a prying tool inserted under the outside of the caps to release the clips, particularly in the front and rear corners, however most of the clips holding the caps in place can be accessed from inside the wellside using pliers.

Repeat for both sides.

3

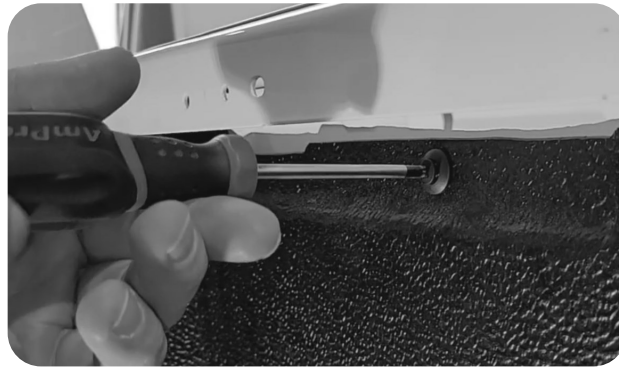

Bolt jamming risk
See Page 2



Bolt jamming risk
See Page 2

Remove the hooks from the front corner

If you have a plastic liner, remove the front clip and bolt holding the liner in the front corner.

Repeat for both sides.

4

This step is only for plastic tub liners. If you have a spray liner or no liner refer to the spray liner sealing kit



Again if you have a plastic tub liner, pull back the liner in the front corners and install the rubber gasket PRT-005961 (4) behind.

Bolt through the gasket into the thread using the following fasteners:

- 7) M8 x 25mm Btn Bolt
- 8) M8 Spring Washer
- 9) M8 Medium Washer

5

This step is only for plastic tub liners. If you have a spray liner or no liner refer to the spray liner sealing kit



Bolt jamming risk
See Page 2

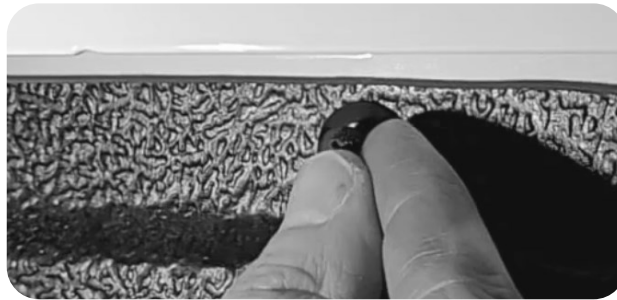

Re-install the front bolt through the plastic liner, ensure it also goes through the second hole in the rubber gasket.

Re-install the liner clip.

Repeat for opposite side.

6

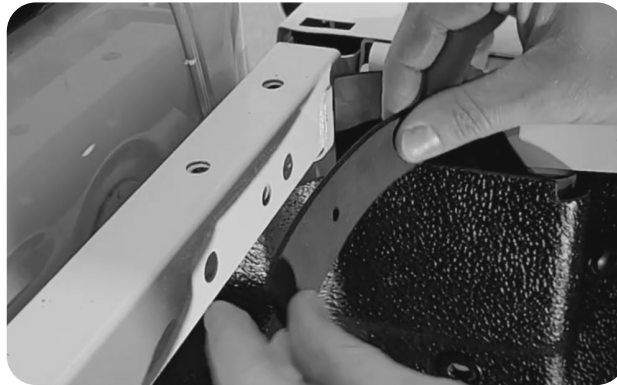

Install the foam gasket PRT-005963 (5) to the front wall, over the thread.

Ensure it covers both open holes.

7



Remove the bolt in the rear corners.

8

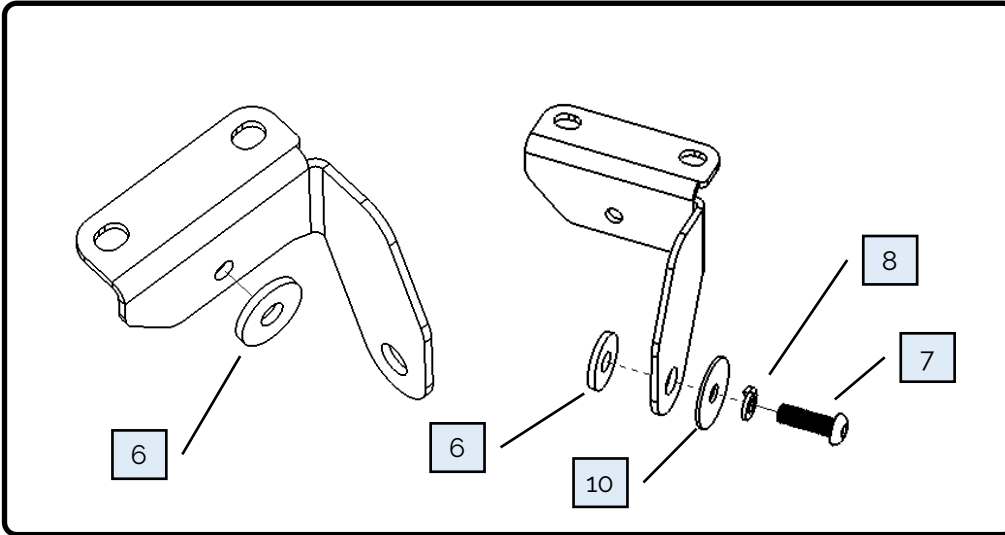

Pre-thread the following fasteners through the rear mounting bracket PRT-005979 (2).

- 7) M8 x 25mm Btn Bolt
- 8) M8 Spring Washer
- 10) M8 Fender Washer

Place PRT-005990 (6) packer on the inside of each bolt hole.

9

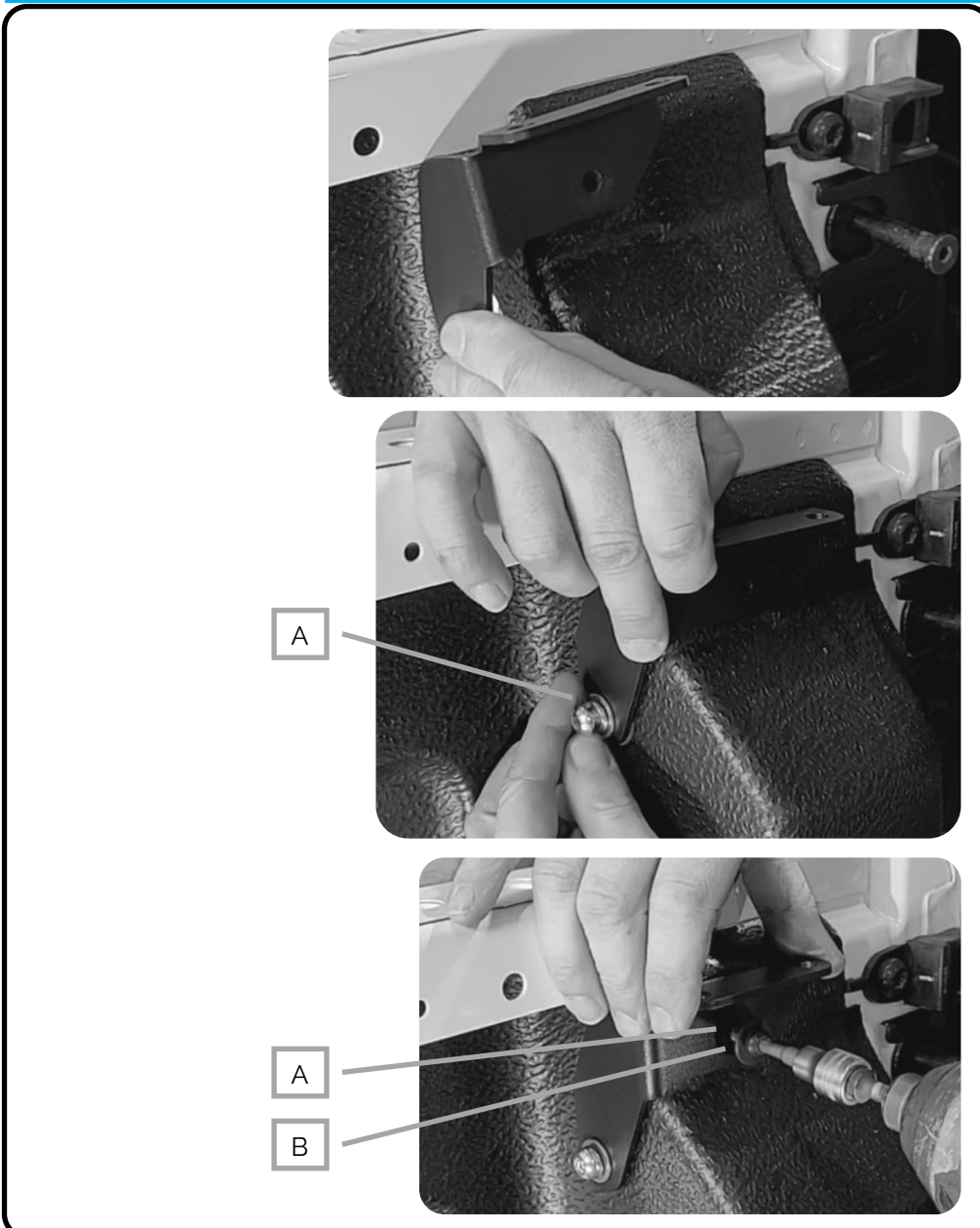

Install the rear mounting bracket PRT-005979 (2) using the fasteners listed in the previous step.

Ensure the packer PRT-005990 (6) sits between the bracket and the vehicle (A).

Re-use the bolt from Step 7 (B), re-install through the bracket.

10



C

Install the front mounting bracket PRT-006870 (3) using the original hook and bolts (C).

Also bolt through the bracket into the front wall thread, using the following fasteners:

- 7) M8 x 25mm Btn Bolt
- 8) M8 Spring Washer
- 9) M8 Medium Washer



Bolt jamming risk
See Page 2



11



Lift the canopy onto the vehicle.

12



Bolt through the canopy into the front mounting brackets using the following fasteners:

- 7) M8 x 25mm Btn Bolt
- 10) M8 Fender Washer
(Top and bottom)
- 11) M8 Nyloc Nut

13



Bolt through the canopy into the rear mounting brackets using the following fasteners:

- 7) M8 x 25mm Btn Bolt
- 9) M8 Medium Washer
(Top and bottom)
- 11) M8 Nyloc Nut

14



Pull up a small section of the weather seal around the side door where this central hole is located

Bolt through to the wellside on both sides using the following:

- 12) M8 x 16mm bolt
- 8) M8 spring washer
- 9) M8 flat washer

15



Remove the top row of screws from the tailgate.

16

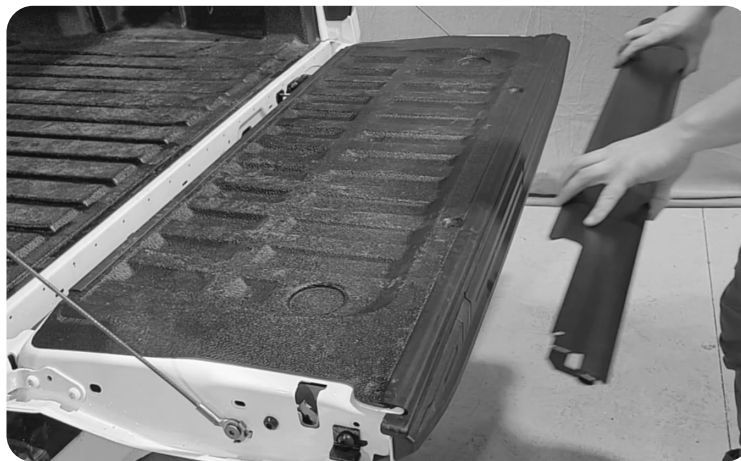

D



Sit the tailgate bracket PRT-005987 (1) in position, so the end tabs hook underneath the plastic liner.

Screw in position using the original screws (D).



Your canopy is now fully fitted and ready to use.
Thank you again for using Utemaster and don't forget to keep checking our website for our latest innovations!