









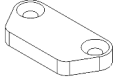
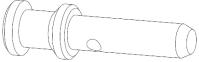
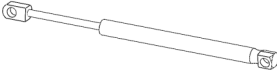

Ford Ranger WildTrak 2022+

GearForce Tub Platform

Despatch List:

ID#	DESCRIPTION	IMAGE	QTY
[1]	Base Brackets (PRT-006985-01L) (PRT-006985-01R)		1x
[2]	Base Hinge Brackets (PRT-006985-02L) (PRT-006985-02R)		1x
[3]	Lock Catch (PRT-006985-03L) (PRT-006985-03R)		1x
[4]	Packer Plate (PRT-006985-04)		2x
[5]	Hinge Pin PRT-006982		2x
[6]	365L300N Gas Strut		2x
[7]	M6 x 16 Btn Head Bolt		14x
[8]	M6 x 25 Countersunk Bolt (AFH6X25A2)		4x
[9]	M6 Spring Washer		14x
[11]	Thread Plate (PRT-007047)		18x
[12]	R-Clip		2x
[13]	M6 Lock Washer		4x
[14]	Padlock and Key		1x



NZ Support:

P: 0800 683 352

E: sales@utemaster.co.nz

W: www.utemaster.co.nz

Australia Support:

P: 1800 769 577

E: sales@utemaster.com.au

W: www.utemaster.com.au

Intentionally blank



bit.ly/3QJZUgR

Ford Ranger WildTrak 2022+ GearForce Tub Platform



Fitting Time:
45 mins

Ensure you have a GearForce Fit Kit installed before installing GearForce Products.

1

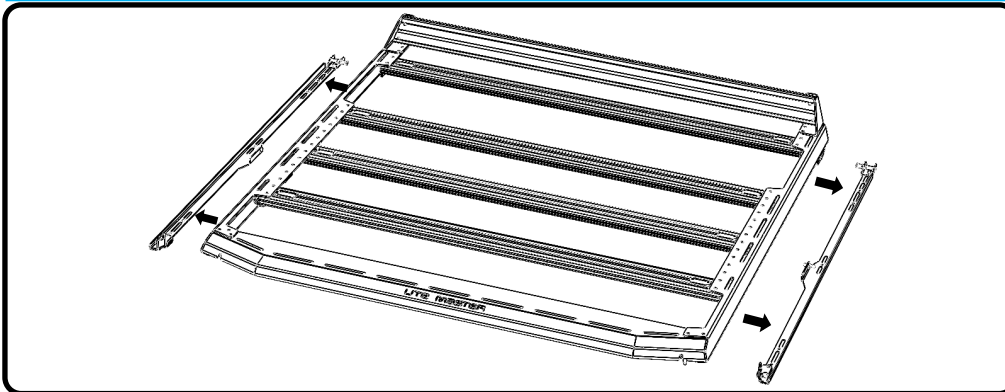

Separate the base brackets **[1]** from the assembled platform

2



Slide 9x thread plates **[11]** in from the front of each T-track on the WildTrak

3



Line up the Platform base bracket **[1]** with the side of the track. This bracket will be used to get an approximate position for the thread plates in the next step

4



Slide the thread plates down the track and line each one up roughly with the circled positions on the base brackets.

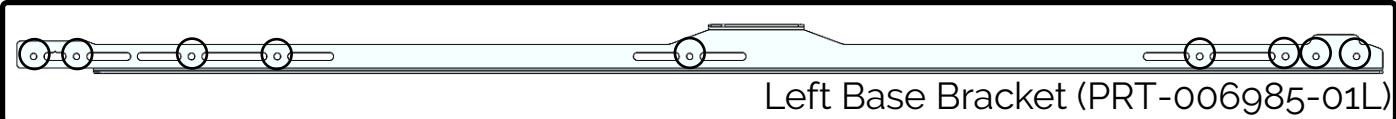
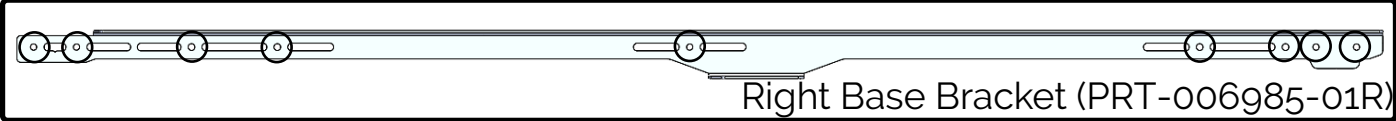

5

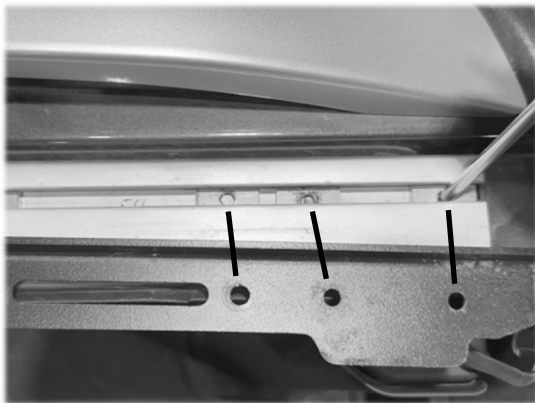

Slide the rear most thread plate all the way until it makes contact with the end. This thread plate dictates the final position of the bracket so ensure it stays hard against the rear.

Once all the thread plates are lined up in their respective positions, place the bracket over the track.

6

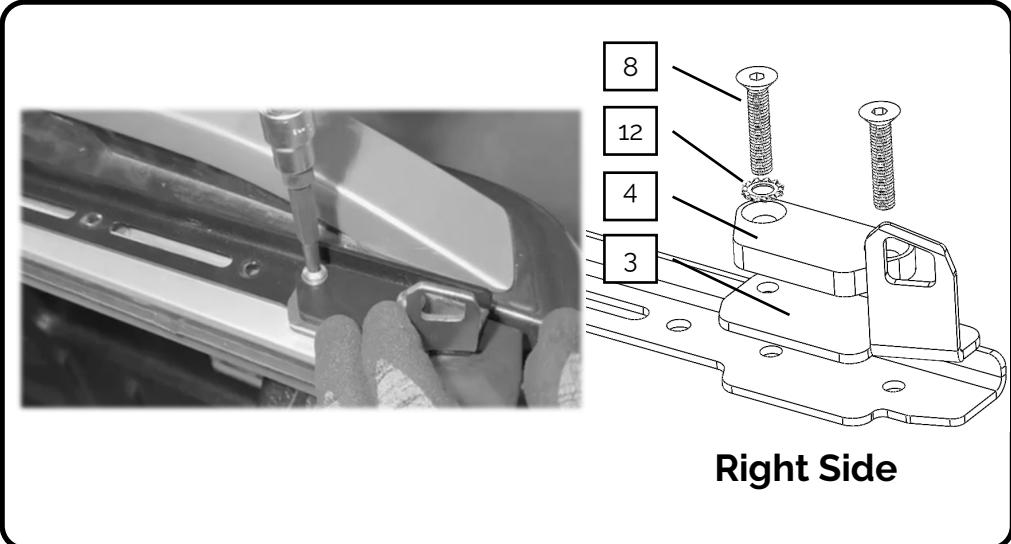

Bolt down the lock catch **[3]** with a packer plate **[4]** to the rear most position on the base bracket. Ensure the bolts are going through in to a thread plate underneath

- [8]** 2x M6 x 25 CSK Bolt
- [12]** 2x M6 Lock Washer

Leave these bolts loose and repeat this step on both sides

7

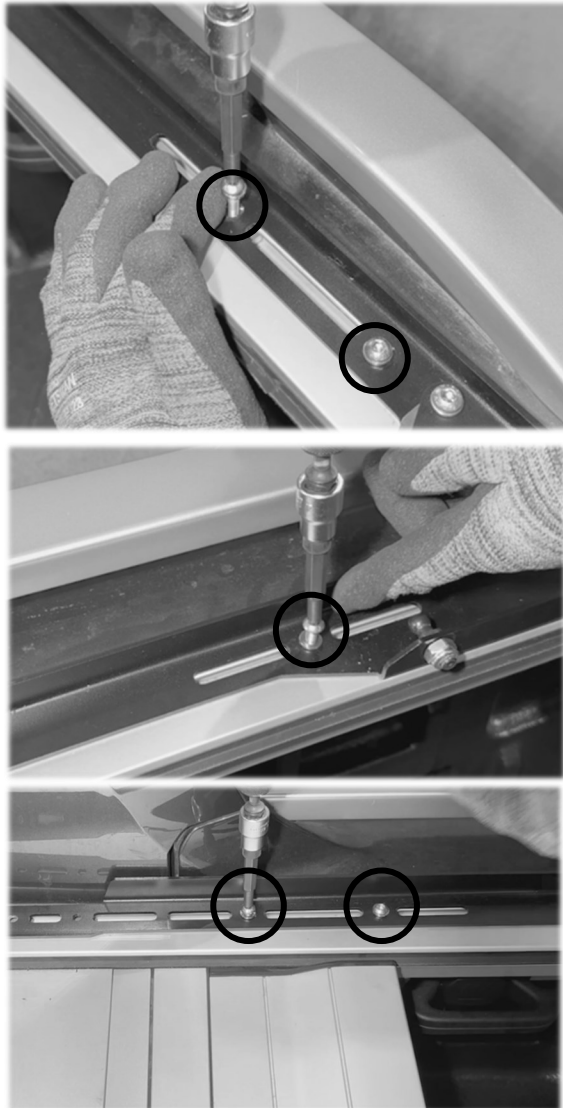

Bolt the base bracket **[1]** down to the thread plates in the 5 circled locations. Use the following fasteners:

- [7]** 5x M6 Btn Head Bolt
- [9]** 5x M6 Spring Washer

Leave the two front-most bolt holes and repeat this process for both sides

8



Bolt down the Base hinge bracket **[2]** using the following fasteners:

- [7]** 2x M6 Btn Head Bolt
- [9]** 2x M6 Spring Washer

Note the orientation of the bracket is as shown

Repeat this for both sides

9



Place the assembled platform onto the base brackets. Make sure the Hinge brackets up the front have slotted in to each other.

10



Install the gas struts [6] to the ball studs on each side as shown.

11



Slide in the hinge pins [5] on both sides.

12



Insert the R-clip **[12]** into the pin hole to secure the platform

This hinge can be locked with the provided padlock to ensure your platform is secure

13

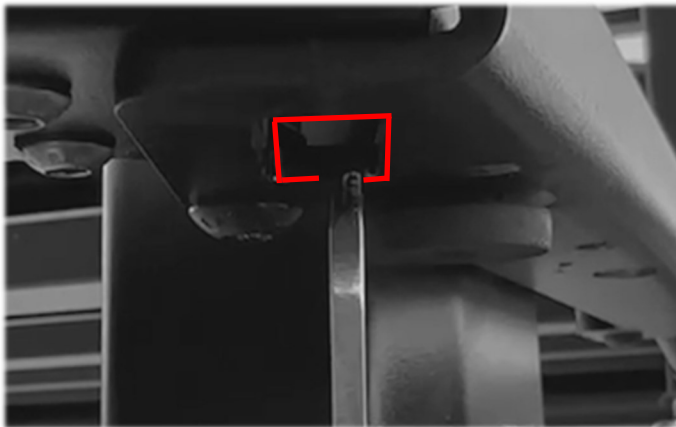

Adjust the rear lock catch to line up roughly in the middle of the adjacent slot in the platform. Once in position, tighten the two countersunk bolts that were left loose in step 6.

14



Open and close the platform to test whether the lock catches are in the correct position.

Your GearForce Tub Platform is now fully fitted and ready to use.
Thanks again for choosing Utemaster and don't forget to keep checking our website for our latest innovations!